

# ELECTRICAL ENGINEERING

## ELECTRICAL MACHINES



Comprehensive Theory  
*with Solved Examples and Practice Questions*





**MADE EASY Publications Pvt. Ltd.**

**Corporate Office:** 44-A/4, Kalu Sarai (Near Hauz Khas Metro Station), New Delhi-110016 | **Ph. :** 9021300500

**Email :** infomep@madeeasy.in | **Web :** www.madeeasypublications.org

## Electrical Machines

Copyright © by MADE EASY Publications Pvt. Ltd.  
All rights are reserved. No part of this publication may be reproduced, stored in or introduced into a retrieval system, or transmitted in any form or by any means (electronic, mechanical, photo-copying, recording or otherwise), without the prior written permission of the above mentioned publisher of this book.



**MADE EASY Publications Pvt. Ltd.** has taken due care in collecting the data and providing the solutions, before publishing this book. In spite of this, if any inaccuracy or printing error occurs then **MADE EASY Publications Pvt. Ltd.** owes no responsibility. We will be grateful if you could point out any such error. Your suggestions will be appreciated.

## EDITIONS

First Edition : 2015  
Second Edition : 2016  
Third Edition : 2017  
Fourth Edition : 2018  
Fifth Edition : 2019  
Sixth Edition : 2020  
Seventh Edition : 2021  
Eighth Edition : 2022  
Ninth Edition : 2023  
Tenth Edition : 2024  
Eleventh Edition : 2025  
**Twelfth Edition : 2026**

# CONTENTS

## Electrical Machines

### CHAPTER 1

#### Magnetic Circuits..... 1-11

1.1	Magnetic Circuits .....	1
1.2	Leakage Flux.....	5
1.3	Induced EMF.....	6
	<i>Objective Brain Teasers</i> .....	7
	<i>Conventional Brain Teasers</i> .....	10

### CHAPTER 2

#### Transformer..... 12-88

2.1	Transformer Construction.....	12
2.2	Operating Principle.....	14
2.3	Primary and Secondary .....	15
2.4	E.M.F. Equation of Transformer.....	15
2.5	Ampere-Turns Relation .....	17
2.6	Winding Resistance and Leakage Reactance .....	18
2.7	Dot Convention in Transformer .....	18
2.8	Ideal Transformer .....	19
2.9	Rating of Transformers.....	23
2.10	Exact Equivalent Circuit of a Transformer .....	23
2.11	Complete Phasor Diagram of Step Down Transformer [ $N_1 > N_2$ ].....	23
2.12	Simplification of Exact Equivalent Circuit .....	25
2.13	Approximate Equivalent Circuit Referred to Primary .....	28
2.14	Approximate Equivalent Circuit Referred to Secondary Side.....	28
2.15	Final Approximate Equivalent Circuit.....	28
2.16	Per Unit Value .....	29
2.17	Testing of Transformers .....	30
2.18	Voltage Regulation.....	33
2.19	Losses and Efficiency .....	37
2.20	Transformer Efficiency.....	37
2.21	Losses.....	37

2.22	Maximum Efficiency .....	39
2.23	Efficiency Considerations In Power Transformer & Distribution Transformer .....	44
2.24	All Day Efficiency.....	45
2.25	Auto Transformer .....	47
2.26	Tertiary Winding.....	51
2.27	3-Phase Transformers .....	53
2.28	3- $\phi$ Transformer Connections.....	54
2.29	Open Delta or V-Connection .....	59
2.30	3- $\phi$ to 2- $\phi$ Conversion (Scott Connection) .....	61
2.31	Parallel Operation of Transformer .....	63
2.32	Load Sharing.....	64
2.33	Magnetizing Current Phenomenon .....	69
2.34	Magnetostriction .....	71
2.35	Conservator and Breather.....	71
	<i>Objective Brain Teasers</i> .....	72
	<i>Conventional Brain Teasers</i> .....	80

### CHAPTER 3

#### Basics of Electromechanical Energy Conversion.....89-109

3.1	Principle of Energy Conversion.....	89
3.2	Coupling-Field Reaction.....	91
3.3	Energy in Magnetic System (Field Energy and Co-energy).....	92
3.4	Field Energy and Mechanical Force.....	95
3.5	Multiple-Excited Magnetic Field Systems .....	99
3.6	Energy Conversion in Electric Field .....	103
3.7	Dynamical Equations of Electromechanical Systems.....	105

### CHAPTER 4

#### Basic Concept of Rotating Electric Machines..... 110-124

4.1	Introduction.....	110
-----	-------------------	-----

4.2	Basic Structure of Rotating Electric Machines.....	110
4.3	Elementary Machines.....	110
4.4	MMF Space Wave of a Concentrated Coil .....	113
4.5	MMF of Distributed Single-Phase Winding .....	114
4.6	MMF of Three-Phase Windings, Rotating Magnetic Field .....	115
4.7	Generated Voltages in AC Machines.....	117
4.8	Machine Torques .....	118
4.9	Losses and Efficiency.....	121
	<i>Objective Brain Teasers</i> .....	123

## CHAPTER 5

### Direct Current Machine ..... 125-211

5.1	Basic of Electric Machines.....	125
5.2	Fleming's Right-Hand Rule and Left-Hand Rule.....	125
5.3	D.C. Machine Construction.....	125
5.4	Magnetic Circuit of D.C. Generator.....	127
5.5	Equivalent Circuit of D.C. Machine Armature .....	127
5.6	Types of D.C. Machine .....	128
5.7	Direct Current Machines Operation.....	128
5.8	E.M.F. Equation of D.C. Machine .....	129
5.9	Torque Equation.....	130
5.10	Types of Armature Windings .....	132
5.11	Methods of Excitation .....	138
5.12	Classification of Direct Current Machines.....	143
5.13	Power Balance in Direct Current Machine .....	143
5.14	Separately Excited Machine ( $V_{BD}$ Neglected) .....	144
5.15	Shunt Excited Machine .....	144
5.16	Long Shunt Generator .....	145
5.17	Short Shunt Generator.....	145
5.18	Condition for Maximum Power Transfer.....	145
5.19	Maximum Efficiency .....	147
5.20	Armature Reaction .....	149
5.21	Commutation .....	153
5.22	Compensating Winding.....	155
5.23	Interpoles.....	157
5.24	Operating Characteristic of D.C. Generators.....	159
5.25	Operating Characteristics of D.C. Motors.....	167
5.26	Starting of D.C. Motors.....	173
5.27	Three-Point D.C. Shunt Motor Starter.....	174
5.28	Four-Point Starter .....	175

5.29	Two-Point Starter .....	175
5.30	D.C. Shunt Motor Starter Design .....	176
5.31	Speed Control of D.C. Motors.....	179
5.32	Testing of D.C. Machines .....	186
5.33	Electric Braking of D.C. Motors.....	190
5.34	Types of Electric Braking .....	190
5.35	Present-Day Uses of D.C. Machines .....	193
	<i>Objective Brain Teasers</i> .....	194
	<i>Conventional Brain Teasers</i> .....	204

## CHAPTER 6

### Synchronous Machine ..... 212-286

6.1	Advantages of Rotating Field Alternator .....	213
6.2	Construction of Three-Phase Synchronous Machines.....	213
6.3	Speed and Frequency .....	215
6.4	Excitation Systems for Synchronous Machines.....	216
6.5	Voltage Generation.....	217
6.6	E.M.F. Equation of Alternator .....	218
6.7	Armature Windings .....	219
6.8	Flux & MMF Phasors in Synchronous Machines.....	228
6.9	Synchronous Machine Phasor Diagram .....	232
6.10	Open Circuit Characteristics .....	234
6.11	Short Circuit Characteristics.....	234
6.12	Zero Power Factor Characteristics .....	235
6.13	Methods to Determine Voltage Regulation .....	237
6.14	Power Angle Equation .....	242
6.15	(A) Effect of Change in Excitation at Constant (KW) Load .....	244
6.15	(B) Effect of Change in Load (KW) at Constant Excitation .....	245
6.16	V-Curve .....	246
6.17	Compounding Curve.....	247
6.18	Synchronous Condenser .....	248
6.19	Transition from Generator to Motor Action .....	250
6.20	Prime-Mover Characteristics.....	252
6.21	Parallel Operation of Alternators.....	253
6.22	Synchronizing Procedure.....	254
6.23	Synchronizing by a Synchroscope.....	256
6.24	Operation of Generator .....	258
6.25	Starting of Synchronous Motors .....	261

6.26	Hunting or Phase Swinging .....	262
6.27	Comparison between 3-Phase Synchronous and Induction Motors .....	263
6.28	Applications of Synchronous Motors .....	264
6.29	Salient Pole Machines .....	264
	<i>Objective Brain Teasers</i> .....	273
	<i>Conventional Brain Teasers</i> .....	278

## CHAPTER 7

### Three Phase Induction Machine .....287-344

7.1	Stator .....	287
7.2	Rotor .....	288
7.3	Induction Motor as a Transformer .....	288
7.4	Difference between IM and Transformer.....	289
7.5	Production of Rotating Field.....	289
7.6	Principle of Operation .....	291
7.7	Frequency of Induced Emf .....	292
7.8	Stator Fed Induction Motor.....	293
7.9	Rotor Fed Induction Motor.....	294
7.10	Equivalent Circuit of 3- $\phi$ Induction Motor .....	294
7.11	Exact Equivalent Circuit Referred to Stator .....	295
7.12	Power Flow in 3- $\phi$ Induction Motor.....	296
7.13	Computational Convenience in Steinmetz Model.....	297
7.14	Thevenin's Equivalent of 3- $\phi$ Induction Motor (Steinmetz Model) .....	298
7.15	For Low Slip Region (Normal Operating Region) ...	299
7.16	For High Slip Region (Starting Region or Braking Region) .....	299
7.17	Maximum Torque or Breakdown Torque or Pull Out Torque or Stalling Torque .....	300
7.18	Slip at Maximum Torque.....	300
7.19	Determination of Equivalent Circuit from No-Load & Blocked Rotor Tests .....	304

7.20	Circle Diagram.....	305
7.21	Construction of Circle Diagram .....	306
7.22	Performance Characteristics (Load) of Induction Motor .....	309
7.23	Starters.....	310
7.24	Magnetic Locking (Cogging) .....	315
7.25	Crawling .....	315
7.26	Deep Bar Rotor.....	317
7.27	Starting Technique of Slip-Ring Induction Motor ..	319
7.28	Speed Control of Induction Motor .....	320
7.29	Double Cage Rotor .....	323
7.30	Induction Generator .....	324
	<i>Objective Brain Teasers</i> .....	326
	<i>Conventional Brain Teasers</i> .....	335

## CHAPTER 8

### Fractional Kilowatt Motors..... 345-368

8.1	Introduction.....	345
8.2	Single-Phase Induction Motors .....	345
8.3	Double Revolving Field Theory.....	346
8.4	Equivalent Circuit of Single Phase Induction Machine .....	348
8.5	Split-Phase Motors .....	354
8.6	Types of Capacitor Split-Phase Motors .....	355
8.7	Shaded-Pole Motor .....	357
8.8	Applications.....	358
8.9	Single-Phase Synchronous Motors.....	359
8.10	Two-Phase Servomotor .....	360
8.11	Stepper Motors.....	361
8.12	Types of Stepper Motors .....	362
8.13	Series Motor-Universal Motor .....	365
	<i>Objective Brain Teasers</i> .....	366



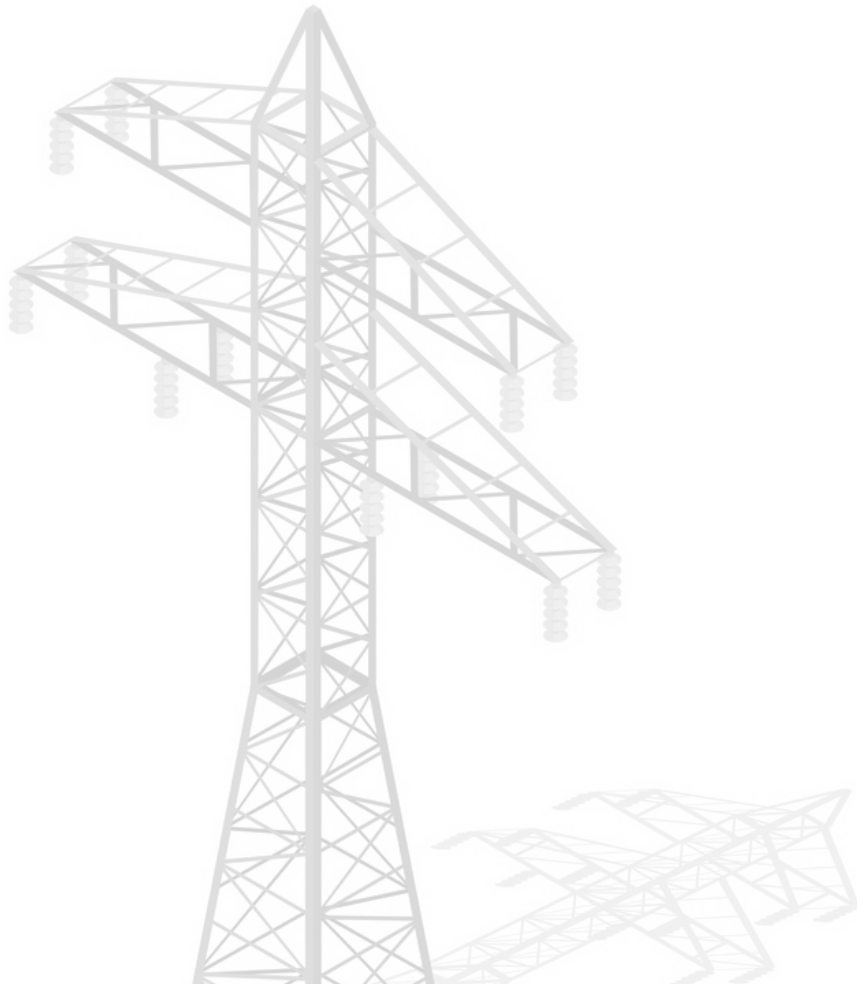

# Magnetic Circuits

## Introduction

The electromagnetic system is an essential element of all rotating electric machinery, electromechanical devices and static devices like the transformer. The role of electro-magnetic system is to establish and control electromagnetic fields for carrying out conversion of energy, its processing and transfer. Electromechanical energy conversion takes place via the medium of a magnetic field or electrical field, but most practical converters use magnetic field as the coupling medium between electrical and mechanical systems. In transformers, the electrical energy is transferred from one electrical circuit to another electrical circuit via the medium of a magnetic field as the coupling medium between two electrical circuits. This is due to fact that the energy storing capacity of magnetic field is much greater than that of the electric field.

## 1.1 MAGNETIC CIRCUITS

- The complete closed path followed by the lines of flux is called a magnetic circuit. In low power electrical machines, magnetic field is produced by permanent magnets. But in high-power electrical machinery and transformers, coupling magnetic field is produced by electric current.
- In a magnetic circuit, the magnetic flux is due to the presence of a magnetomotive force same as in an electric circuit, the current is due to the presence of a electromotive force.
- The mmf is created by a current flowing through one or more turns.

$$MMF = \text{Current} \times \text{Number of turns in the coil}$$

$$f = MMF = NI \text{ (ampere-turns) or (ATs)}$$

- The magnetic flux  $\phi$  may be defined as the magnetomotive force per unit reluctance.

$$\phi = \frac{MMF}{\text{Reluctance}}$$

where reluctance in magnetic circuit is similar as resistance in electric circuit.

- The opposition offered to the magnetic flux is called reluctance,

$$Rl = \frac{l}{\mu A} \text{ AT/wb}$$

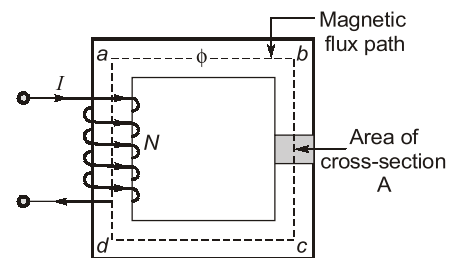

Fig. : Magnetic circuit

where,  $l$  = length of the magnetic path;  $A$  = area of cross-section normal to flux path,  $m^2$ .

$\mu = \mu_0 \mu_r$  = permeability of the magnetic material

$\mu_r$  = relative permeability of magnetic material;  $\mu_0$  = permeability of free space =  $4\pi \times 10^{-7}$  H/m.

The permeance of a magnetic circuit is the reciprocal of its reluctance.

$$P = \frac{1}{R_l}$$

Reluctances in a magnetic circuit obey the same rules as resistances in an electric circuit. The equivalent reluctance of a number of reluctances in series is the sum of the individual reluctances :

$$R_{l_{eq}} = R_{l_1} + R_{l_2} + R_{l_3} + \dots$$

Permeances in series and parallel obey the same rules as electrical conductances.

### 1.1.1 Core with Air-Gap

A typical magnetic circuit with an air-gap is shown below in the figure. It is assumed that the air-gap is narrow and the flux coming out of the core passes straightly through the air-gap, such that the flux density in the air-gap is the same as in the core and core permeability  $\mu$  is regarded as constant (linear magnetization). But in reality the flux in the air-gap fringes out so that the air-gap flux density is somewhat less than that of the core (fringing effect).

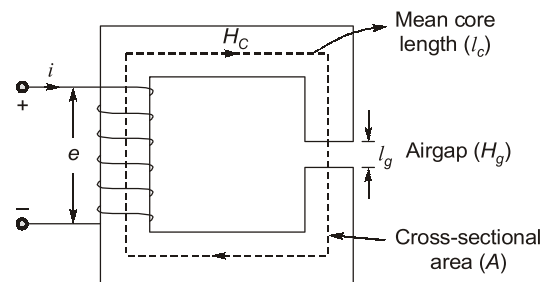

$$\text{MMF } Ni \text{ is now given as : } Ni = H_c l_c + H_g l_g = \frac{B_c}{\mu_c} l_c + \frac{B_g}{\mu_0} l_g$$

Assuming that all the core flux passes straight down the air-gap (it means no fringing),

$$B_c = B_g$$

$\therefore$

$$\phi = B_c A = B_g A$$

$\therefore$

$$N_i = \phi \left( \frac{l_c}{\mu_c A} \right) + \phi \left( \frac{l_g}{\mu_0 A} \right) \Rightarrow N_i = \phi (R_{l_c} + R_{l_g})$$

where,  $R_{l_c} = \frac{l_c}{\mu_c \cdot A}$  = core reluctance ;  $R_{l_g} = \frac{l_g}{\mu_0 A}$  = air-gap reluctance

The magnetic energy stored in the air-gap and the iron core is given as

$$W = \frac{1}{2} LI^2 = \frac{1}{2} \left( \frac{N^2}{\text{Reluctance}} \right) \times I^2 = \frac{1}{2 \times \text{Reluctance}} \times (\phi \times \text{Reluctance})^2 = \frac{1}{2} \phi^2 R_T$$

where  $R_T$  is total reluctance that is  $R_T = R_{l_c} + R_{l_g}$ .

### 1.1.2 Fringing

At an air-gap in a magnetic core, the flux fringes out into neighbouring paths as shown in figure. The result is non-uniform flux density in the air-gap, enlargement of the effective air-gap area and a decrease in the average air-gap flux density.

If area of air-gap increases, then total area of core with consideration of air gap increases. Then average flux density gets reduced. It is possible to partially offset these inherent sources of error by using a "corrected" or "effective" mean path length and the cross-sectional area instead of actual physical length and area in the calculations. Satisfactory results may be achieved with this approximate method.

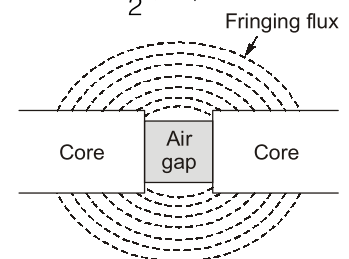

**EXAMPLE : 1.1**

An iron ring with a mean length of magnetic path of 20 cm and of small cross-section has an air gap of 1 mm. It is wound uniformly with a coil of 440 turns. A current of 1 A in the coil produces a flux density of  $16\pi \times 10^{-3} \text{ Wb/m}^2$ . Neglecting leakage and fringing, calculate the relative permeability of iron.

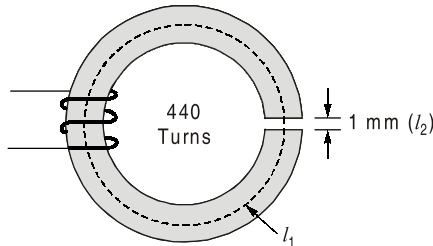

**Solution :**

The figure shows an iron ring of mean length

$$= 20 \text{ cm} = l_1$$

Length of air gap = 1 mm =  $1 \times 10^{-3} \text{ m} = l_2$

Number of turns would = 440 turns =  $N$

$$\text{Current in the coil} = 1 \text{ A} = I$$

$$\text{Flux density} = 16\pi \times 10^{-3} \text{ Wb/m}^2 = B$$

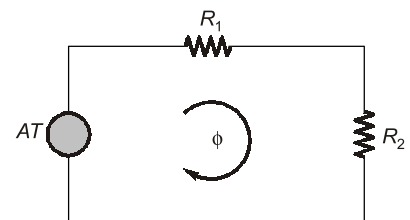

The electrical equivalent is as shown given figure.

Here,

$R_1$  = Reluctance of iron;  $R_2$  = Reluctance of air gap.

$\therefore$

$$AT = \phi(R_1 + R_2) \Rightarrow \phi = BA \quad (A = \text{Area})$$

$$AT = BA \left( \frac{l_1}{\mu_0 \mu_r A} + \frac{l_2}{\mu_0 A} \right) = \frac{B}{\mu_0} \left[ \frac{l_1}{\mu_r} + l_2 \right]$$

$\therefore$

$$\frac{l_1}{\mu_r} + l_2 = \frac{\mu_0 AT}{B} = \frac{4\pi \times 10^{-7} \times 440 \times 1}{16\pi \times 10^{-3}}$$

$$\frac{20 \times 10^{-2}}{\mu_r} + 1 \times 10^{-3} = 110 \times 10^{-4}$$

$\therefore$

$$\mu_r = \frac{20 \times 10^{-2}}{10 \times 10^{-3}} = 20$$

**EXAMPLE : 1.2**

A magnetic core is excited with two different arrangements of exciting coils as shown in figure. The resistance of the exciting coils is negligible. The same sinusoidal voltage at a specified frequency is applied to the exciting coil in each case. If the flux density and the exciting current in case (a) are  $B = 0.1 \text{ tesla}$  and  $I = 8 \text{ A}$ , calculate the values of these quantities in case (b).

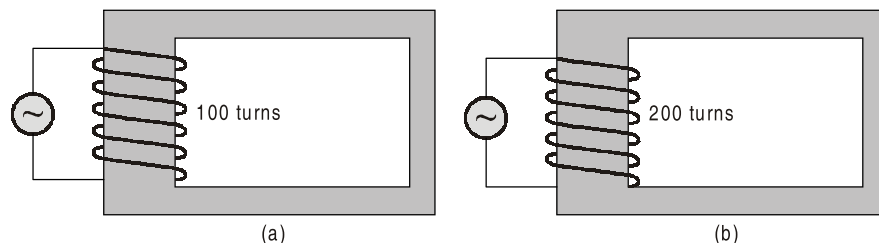

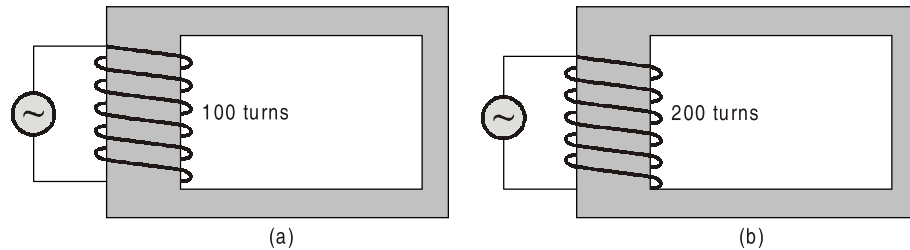
**Solution :****Method-1 :** The resistance of exciting coil is negligible,

$$B_1 = 0.1 \text{ tesla}, I_1 = 8 \text{ A}$$

$$\text{We know, } AT = \text{flux} \times \text{reluctance}, \therefore AT = \phi \times \frac{\ell}{\mu_0 \mu_r A} = B \times \frac{\ell}{\mu_0 \mu_r}$$

$$\text{Since } B = \frac{\phi}{A},$$

$$AT = \text{Ampere-turns} = I \times N \quad (N = \text{Number of turns})$$

$$\therefore I_1 N_1 = B_1 \times \frac{\ell}{\mu_0 \mu_r}$$

$$\text{Similarly, } I_2 N_2 = B_2 \times \frac{\ell}{\mu_0 \mu_r}$$

$$\therefore \frac{I_1 N_1}{I_2 N_2} = \frac{B_1}{B_2} \Rightarrow \frac{8 \times 100}{I_2 \times 200} = \frac{0.1}{B_2}$$

$$\therefore I_2 = 40 B_2$$

$$\text{Induced emf} = -N \frac{d\phi}{dt}$$

$$\therefore \frac{E_1}{E_2} = \frac{-N_1 \frac{d\phi_1}{dt}}{-N_2 \frac{d\phi_2}{dt}} = \frac{N_1}{N_2} \times \frac{\phi_1}{\phi_2} = \frac{N_1 B_1}{N_2 B_2}$$

$$\text{Since } E_1 = E_2 \text{ (same), } N_1 B_1 = N_2 B_2 \Rightarrow 100 \times 0.1 = 200 \times B_2$$

$$\therefore B_2 = \frac{100 \times 0.1}{200} = 0.05 \text{ tesla}$$

$$I_2 = 40(0.05) = 2 \text{ A}$$

**Method-2 :**

$$L \propto N^2$$

$$L_2 = 4L_1$$

$$\Rightarrow X_2 = 4X_1 \quad (\because 2\pi fL_2 = 4(2\pi fL_1); X_2 = 4X_1)$$

$$\Rightarrow I_2 = \frac{1}{4} I_1 \quad \left( \because \frac{E_1}{E_2} = \frac{I_1 X_1}{I_2 X_2} \text{ and } E_1 = E_2 \right)$$

$$MMF_2 = \frac{1}{2} MMF_1$$

$$\text{For same magnetic circuit, } B_2 = \frac{1}{2} B_1 = \frac{0.1}{2} = 0.05 \text{ tesla} \quad (\because MMF \propto \phi \propto \beta)$$

$$I_2 = \frac{1}{4} \times I_1 = \frac{1}{4} \times 8 = 2 \text{ A} \quad (\because MMF \propto \phi \propto \beta)$$

**EXAMPLE : 1.3**

In the magnetic circuit shown in figure, the areas of cross-section of limbs *B* and *C* are resp.  $0.01 \text{ m}^2$  and  $0.02 \text{ m}^2$ . Air gaps of lengths  $1.0 \text{ mm}$  and  $2.0 \text{ mm}$  respectively are cut in the limbs *B* and *C*. If the magnetic medium can be assumed to have infinite permeability and the flux in limb *B* is  $1.0 \text{ Wb}$ . Find the flux in limb *A*?

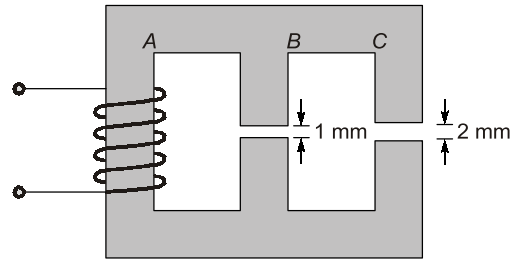

**Solution :**

Area of cross-section of limb *B* =  $0.01 \text{ m}^2$       Area of cross-section of limb *C* =  $0.02 \text{ mm}^2$   
 Air gap length =  $1.0 \text{ mm}$  for limb *B*      Air gap length =  $2.0 \text{ mm}$  for limb *C*  
 Magnetic medium is assumed as infinite permeability

$\therefore$  Reluctance of iron path is zero since  $R \propto \frac{1}{\mu}$

Flux in limb,  $B = 1.0 \text{ Wb}$

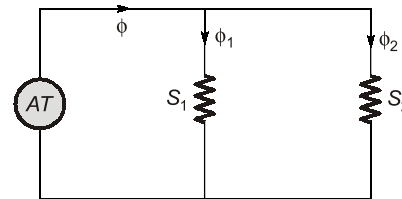
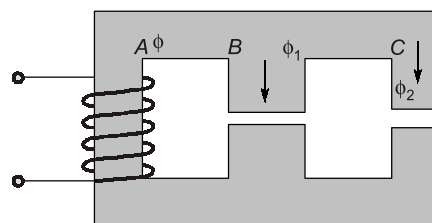

where,  $R_1$  – reluctance of air gap of limb *B*;  $R_2$  – reluctance of air gap of limb *C*  
 $\phi_1$  – flux across air gap of limb *B*;  $\phi_2$  – flux across air gap of limb *C*

$$\therefore R_1 \times \phi_1 = R_2 \times \phi_2$$

$$\therefore \frac{l_1}{\mu_0 \times A_1} \times \phi_1 = \frac{l_2}{\mu_0 \times A_2} \times \phi_2 \Rightarrow \phi_2 = \frac{A_2}{A_1} \times \frac{l_1}{l_2} \times \phi_1 = \frac{0.02}{0.01} \times \frac{1}{2} \times 1 = 1 \text{ Wb}$$

$$\therefore \text{Flux in limb A} = \phi_1 + \phi_2 = 1 \text{ Wb} + 1 \text{ Wb} = 2 \text{ Wb}$$

**1.2 LEAKAGE FLUX**

For an ideal magnetic circuit, we assume that the flux completely flow through the low reluctance path of iron. But in practical case, a small amount of flux produced by a coil or magnetic passes through region of space generally air spaces, electrical insulations, conductor of structural members of the system, rather than along the main path of the magnetic circuit. These flux lines are termed as leakage flux lines. In coupled circuit with two or more windings, the flux which links one coil does not link the other, is known as leakage flux. Its effect on the analysis of electrical machinery is carried out by replacing it by an equivalent leakage reactance

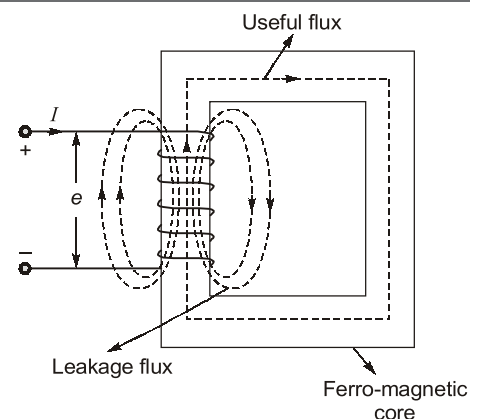

$$L = \frac{\text{Flux linkage}}{\text{Current}} = \frac{\lambda}{I} = \frac{N\phi}{I}$$

## 1.3 INDUCED EMF

### 1.3.1 Faraday's Law of Electromagnetic Induction

According to Faraday's law, whenever the magnetic flux linked with a circuit changes, an emf is induced in it, and magnitude of the induced emf is equal to the rate of change of flux-linkages.

$$e \propto \frac{d\phi}{dt} \propto \frac{d(\phi N)}{dt}$$

$$e = -N \frac{d\phi}{dt}$$

where,

$e$  = induced emf;  $N$  = number of turns in the coil

$\phi$  = flux linkages with the coil ( $N\phi$ );  $t$  = time in seconds

'-' (minus) sign indicates the direction of induced emf which can be found by Lenz's law.

### 1.3.2 Lenz's Law

This law states that, electromagnetically induced current always flows in such direction that the action of the magnetic field set up by it tends to oppose the very cause which produces it.

### 1.3.3 Statically and Dynamically Induced EMF

- If the flux is time-varying in nature, then due to the inherent rate of change it automatically links stationary conductor and induces emf across it. This type of induced emf is called statically induced emf. e.g., transformer.
- If the flux is time-invarying in nature, then it requires a relative motion between flux and the conductor for effective rate of change of flux linkages to get induced emf. This type of induced emf is called dynamically induced emf is called dynamically induced emf. e.g., DC machine, synchronous machine.

#### EXAMPLE : 1.4

The magnetic circuit has dimensions  $A_c = 4 \times 4 \text{ cm}^2$ , mean path length  $l_c = 40 \text{ cm}$ , air-gap length  $l_g = 0.06 \text{ cm}$  and number of turns,  $N = 600$  turns. Assume value of  $\mu_r = 6000$  for iron. Find the following :

- Induced emf for  $B_c = 1.2 \sin 314t \text{ T}$ .
- Core reluctance ( $R_c$ ) and air-gap reluctance ( $R_g$ )
- Coil inductance ( $L$ )

**Solution :**

$$(a) \quad B_c = 1.2 \text{ T}, A_c = 4 \times 4 \text{ cm}^2$$

$$\phi = B_c A_c = 1.2 \times 4 \times 4 \times 10^{-4} = 19.2 \times 10^{-4} \text{ Wb}$$

$$\lambda = N\phi = 600 \times 19.2 \times 10^{-4} = 1.152 \text{ Wb-turns}$$

$$\text{Emf is, } e = \frac{d\lambda}{dt} = \frac{1.152d}{dt}(\sin 314t) = 361.7 \cos 314t \text{ V}$$

$$(b) \quad R_c = \frac{l_c}{\mu_o \mu_r A_c} = \frac{40 \times 10^{-2}}{4\pi \times 10^{-7} \times 6000 \times 4 \times 4 \times 10^{-4}} = 3.316 \times 10^4$$

$$R_g = \frac{l_g}{\mu_o A_g} = \frac{l_g}{\mu_o A_c} = \frac{6 \times 10^{-4}}{4\pi \times 10^{-7} \times 16 \times 10^{-4}} = 29.856 \times 10^4 (\because A_g = A_c)$$

$$(c) \quad Ni = \frac{B_c}{\mu_o \mu_r} l_c + \frac{B_g}{\mu_o} l_g$$

$$i = \frac{B_c}{\mu_o N} \left( \frac{l_c}{\mu_r} + l_g \right) = \frac{1.2}{4\pi \times 10^{-7} \times 600} \left( \frac{40}{6000} + 0.06 \right) \times 10^{-2} \quad (\because B_g = B_c)$$

$$= 1.06 \text{ A}$$

$$L = \frac{\lambda}{i} = \frac{1.152}{1.06} = 1.09 \text{ H}$$



**OBJECTIVE BRAIN TEASERS**

- Q1** A cast steel electromagnet has an airgap of length 2 mm and an iron path of length 30 cm. The number of ampere turns necessary to produce a flux density of 0.8 Wb/m<sup>2</sup> in the gap is \_\_\_\_\_. Neglect leakage and fringing. (For 0.8 Wb/m<sup>2</sup> cast steel requires 750 AT/m).
- Q2** A cast steel ring has a circular cross-section 3 cm in diameter and a mean circumference of 80 cm. The ring is uniformly wound with 600 turns.
- (a) The current required to produce a flux of 0.5 m Wb in the ring is \_\_\_\_ A.
  - (b) If a saw cut 2 mm wide is made in the ring, then approximately the flux produced by the current found in (a) is \_\_\_\_ mWb.
  - (c) The current value which will give the same flux as in (a), after the air gap of 2 mm is made in the ring is \_\_\_\_ A.

Assume the gap density to be the same as in the iron and neglect fringing.

(For 0.705 Wb/m<sup>2</sup> cast steel requires 670 AT/m).

- Q3** An iron ring of mean length 50 cm has an air gap of 1 mm and a winding of 200 turns. If the permeability of the iron is 300 and a current of 1 A flows through the coil, then the flux density is \_\_\_\_\_.
- Q4** Why the transformer stampings are varnished before being used to build the core?
- (a) To increase air-gap between stampings
  - (b) To reduce hysteresis loss

- (c) To reduce eddy current loss
- (d) To provide strength to the core

- Q5** Maximum flux established in an AC excited iron core is influenced by
- (a) frequency only
  - (b) voltage only
  - (c) both voltage and frequency
  - (d) reluctance of the core
- Q6** A circular iron core has an air-gap cut in it and is excited by passing direct current through a coil wound on it. The magnetic energy stored in the air-gap and the iron core is
- (a) in inverse ratio of their reluctance
  - (b) in direct ratio of their reluctances
  - (c) equally divided among them
  - (d) energy resides wholly in the iron core
- Q7** In the electromagnetic relay of given figure below the reluctance of the iron path is negligible. The coil self-inductance is given by the expression

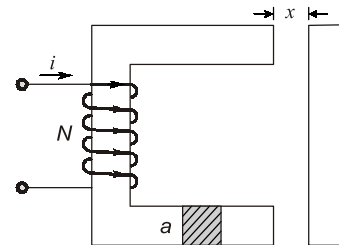

- (a)  $\mu_o N^2 a/x$
  - (b)  $\mu_o N/2 ax$
  - (c)  $\mu_o N^2 a/2x$
  - (d)  $\mu_o N^2/2 ax$
- Q8** An iron-cored choke with 1 mm air-gap length, draws 1 A when fed from a constant voltage AC

source of 220 V. If the length of air-gap is increased to 2 mm, the current drawn by the choke would

- (a) become nearly one half
- (b) remain nearly the same
- (c) become nearly double
- (d) become nearly zero

**Q.9** The unit of inductance is

- (a) Wb T/A
- (b) V s/A
- (c) H-turns<sup>2</sup>
- (d) All are equivalent

**Q.10** Building steel core out of stampings reduces eddy current loss because,

- (a) it increases core resistivity.
- (b) it increases the effective length of eddy current paths thereby increasing effective resistance to the flow of eddy currents.
- (c) it increases core permeability.
- (d) it reduces the effective length of eddy current path, thereby reducing effective resistance to the flow of eddy currents.

**Q.11** In a 4-pole dynamo, the flux/pole is 15 mWb. The average emf induced in one of the armature conductors, if armature is driven at 600 rpm

- (a) 2.5 V
- (b) 0.6 V
- (c) 9 V
- (d) 0.9 V

### ANSWER KEY

1. (1498.24)      2. (Sol)      3. (Sol)      4. (c)  
5. (c)      6. (b)      7. (c)      8. (c)      9. (d)  
10. (b)      11. (b)

### HINTS & EXPLANATIONS

**1. (1498.24)**

Length of iron path,

$$l_i = 30 \text{ cm} = 30 \times 10^{-2} \text{ m}$$

Length of air gap = 2 mm =  $2 \times 10^{-3}$  m

$$B = NI \times \frac{\mu_o \mu_r}{l}$$

$$NI = \frac{Bl}{\mu_o \mu_r}$$

$$NI_{\text{air}} = \frac{0.8 \times 2 \times 10^{-3}}{4\pi \times 10^{-7}} = 1273.24 \text{ AT}$$

$$NI_{\text{cast steel}} = 750 \text{ AT/m} \times l_i \\ = 750 \times 30 \times 10^{-2} = 225 \text{ AT}$$

$$NI_{\text{Total}} = NI_{\text{cast steel}} + NI_{\text{air}} \\ = 1498.24 \text{ AT}$$

**2. (Sol)**

(a) The cross-sectional area

$$= \frac{\pi d^2}{4} \times 10^{-4} = \frac{\pi \times 9}{4} \times 10^{-4} \\ = 7.068 \approx 7.1 \times 10^{-4} \text{ m}^2$$

The flux density,

$$B = \frac{\phi}{A} = \frac{0.5 \times 10^{-3}}{7.1 \times 10^{-5}} = \frac{5}{7.1} \\ = 0.705 \text{ Wb/m}^2$$

$$\therefore \text{AT required} = 670 \times 0.8 = 536$$

$\therefore$  The current required

$$= \frac{\text{AT}}{N} = \frac{536}{600} = 0.89 \text{ A}$$

(b) Flux without air gap = 0.5 mWb

$$\phi = \frac{NI}{S_i}$$

$$0.5 \times 10^{-3} = \frac{600 \times 0.8933}{S_i}$$

$$S_i = \text{Reluctance of iron (steel)} = 1072000$$

$$S_a = \text{Reluctance of air}$$

$$= \frac{2 \times 10^{-3}}{4\pi \times 10^{-7} \times \left(\pi \times \frac{d^2}{4}\right)} = 2251581.9$$

$$S_T = \text{Total reluctance} \\ = S_i + S_a = 3323581.9$$

$$\phi_{\text{new}} = \text{new flux with air gap}$$

$$\phi_{\text{new}} = \frac{536}{3323581.9} = 0.16127 \text{ mWb}$$

(c) Ampere turn required =  $NI$

$$= \phi \times S_T (\text{Flux} \times \text{Total Reluctance})$$

$$= (0.5 \times 10^{-3}) \times (3323581.9)$$

$$NI = 1661.8 \text{ AT}$$

$$I = \frac{1661.8}{600} = 2.769 \text{ A}$$

**3. (Sol)**

The reluctance,  $R = \frac{l}{A\mu}$

$\therefore$  The total reluctance =  $R_1 + R_2$

$$= \frac{1 \times 10^{-3}}{A\mu_0} + \frac{0.5}{300A\mu_0} = \frac{8 \times 10^{-3}}{3A\mu_0} \text{ AT/Wb}$$

$\therefore$  The total flux =  $\frac{\text{Total AT}}{\text{Reluctance}} = \frac{200 \times 1 \times 3A\mu_0}{8 \times 10^{-3}}$

$\therefore$  The flux density =  $\frac{600 \times \mu_0}{8 \times 10^{-3}} \text{ Wb/m}^2$

$$= \frac{600 \times 4\pi \times 10^{-7}}{8 \times 10^{-3}} = 94.2 \text{ mWb/m}^2$$

**4. (c)**

In order to reduce the eddy current losses, laminations made in the core are insulated from one-another by thin layers of varnish.

**5. (c)**

$$\phi \propto \frac{V}{f}, \text{ i.e., flux} \propto \frac{\text{Voltage}}{\text{Frequency}}$$

**6. (b)**

$\therefore W = \frac{1}{2} \phi^2 S$

$\therefore W \propto S(\text{Reluctance})$

**7. (c)**

$$\phi = \frac{NI}{S} = \frac{Ni}{\frac{2x}{\mu_0 a}} = \frac{Ni\mu_0 a}{2x}$$

$\therefore N\phi = Li$

$\therefore L = \frac{N\phi}{i} = \frac{N^2 \mu_0 a}{2x}$

**8. (c)**

$$\phi = \frac{NI\mu_0 A}{l}$$

(ignoring reluctance of iron)

$$I = \frac{l\phi}{N\mu_0 A} \Rightarrow I \propto l$$

$$I' = 2I \text{ for } l' = 2l$$

**9. (d)**

$$LI = N\phi \Rightarrow L = \frac{N\phi}{I} \quad (\text{Unit : WbT/A or Vs/A})$$

$$L = \frac{N^2 \mu \cdot A}{l}$$

$$\text{Unit : Turns}^2 \times \frac{H}{m} \cdot \frac{m^2}{m} = \text{H-turns}^2$$

**10. (b)**

Building steel core out of stampings increases the path of eddy currents, which leads to the increase in effective resistance, thereby reducing eddy current losses.

**11. (b)**

It should be noted that each time the conductor passes under a pole, it cuts a flux of 15 mWb. Hence, the flux cut in one revolution is  $15 \times 4 = 60 \text{ mWb}$ . Since conductor is rotating at  $\frac{600}{60} = 10 \text{ rps}$ .

Time taken for one revolution is  $\frac{1}{10} = 0.1 \text{ sec}$

$\therefore \text{emf} = \frac{Nd\phi}{dt}$

$$d\phi = 6 \times 10^{-2} \text{ Wb}$$

$$dt = 0.1 \text{ sec}$$

$$e = \frac{1 \times 6 \times 10^{-2}}{0.1} = 0.6 \text{ V}$$





## CONVENTIONAL BRAIN TEASERS

- Q.1** For the magnetic circuit of figure find the self and mutual inductances between the two coils. Core permeability = 1600.

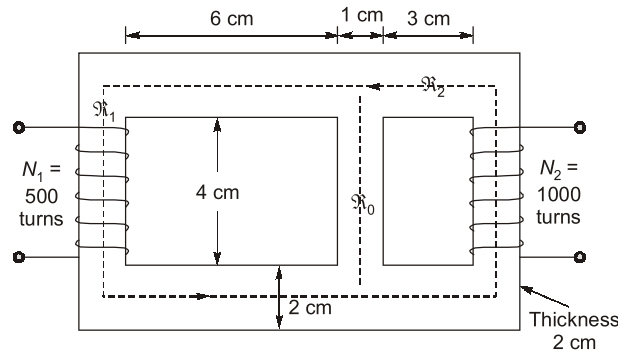

### 1. (Sol)

$$l_1 = (6 + 0.5 + 1) \times 2 + (4 + 2) = 21 \text{ cm}$$

$$l_2 = (3 + 0.5 + 1) \times 2 + (4 + 2) = 15 \text{ cm}$$

$$l_0 = 4 + 2 = 6 \text{ cm}$$

$$R_1 = \frac{21 \times 10^{-2}}{4\pi \times 10^{-7} \times 1600 \times 2 \times 2 \times 10^{-4}} = 0.261 \times 10^6$$

$$R_2 = \frac{15 \times 10^{-2}}{4\pi \times 10^{-7} \times 1600 \times 2 \times 2 \times 10^{-4}} = 0.187 \times 10^6$$

$$R_0 = \frac{6 \times 10^{-2}}{4\pi \times 10^{-7} \times 1600 \times 1 \times 2 \times 10^{-4}} = 0.149 \times 10^6$$

- (i) Coil 1 excited with 1 A :

$$R = R_1 + R_0 \parallel R_2 = 0.261 + 0.1871 \parallel 0.149 = 0.344 \times 10^6$$

$$\phi_1 = \frac{(500 \times 1)}{(0.344 \times 10^6)} = 1.453 \text{ mWb}$$

By flux division (similar to current division) :

$$\phi_{21} = \phi_2 = \frac{1.453 \times 0.149}{(0.149 + 0.187)} = 0.64 \text{ mWb}$$

$$L_{11} = N_1 \phi_1 = 500 \times 1.453 \times 10^{-3} = 0.7265 \text{ H}$$

$$M_{21} = N_2 \phi_{21} = 1000 \times 0.649 \times 10^{-3} = 0.64 \text{ H}$$

- (ii) Coil 2 excited with 1 A :

$$R = R_2 + \frac{(R_0 R_1)}{(R_0 R_1)} = \frac{0.187 + (0.149 \times 0.281)}{(0.149 + 0.281)} \times 10^6 = 0.284 \times 10^6$$

$$\phi_2 = \frac{(1000 \times 1)}{(0.284 \times 10^6)} = 3.52 \text{ mWb}$$

$$L_{22} = N_2 \phi_2 = 1000 \times 3.52 \times 10^{-3} = 3.52 \text{ H}$$

$$M_{12} = M_{21} \text{ (bilateral)} = 0.65 \text{ H}$$